

# Machine Learning 2

DS 4420 - Spring 2020

Sequence-2-sequence models

Byron C. Wallace



# Today

- Learning to map between sequences

# Today

- Learning to map between sequences

Input

$\mathbf{x}_1$

$\mathbf{x}_2$

...

$\mathbf{x}_{T-1}$

$\mathbf{x}_T$

Output



Input



# Motivating Example: Translation

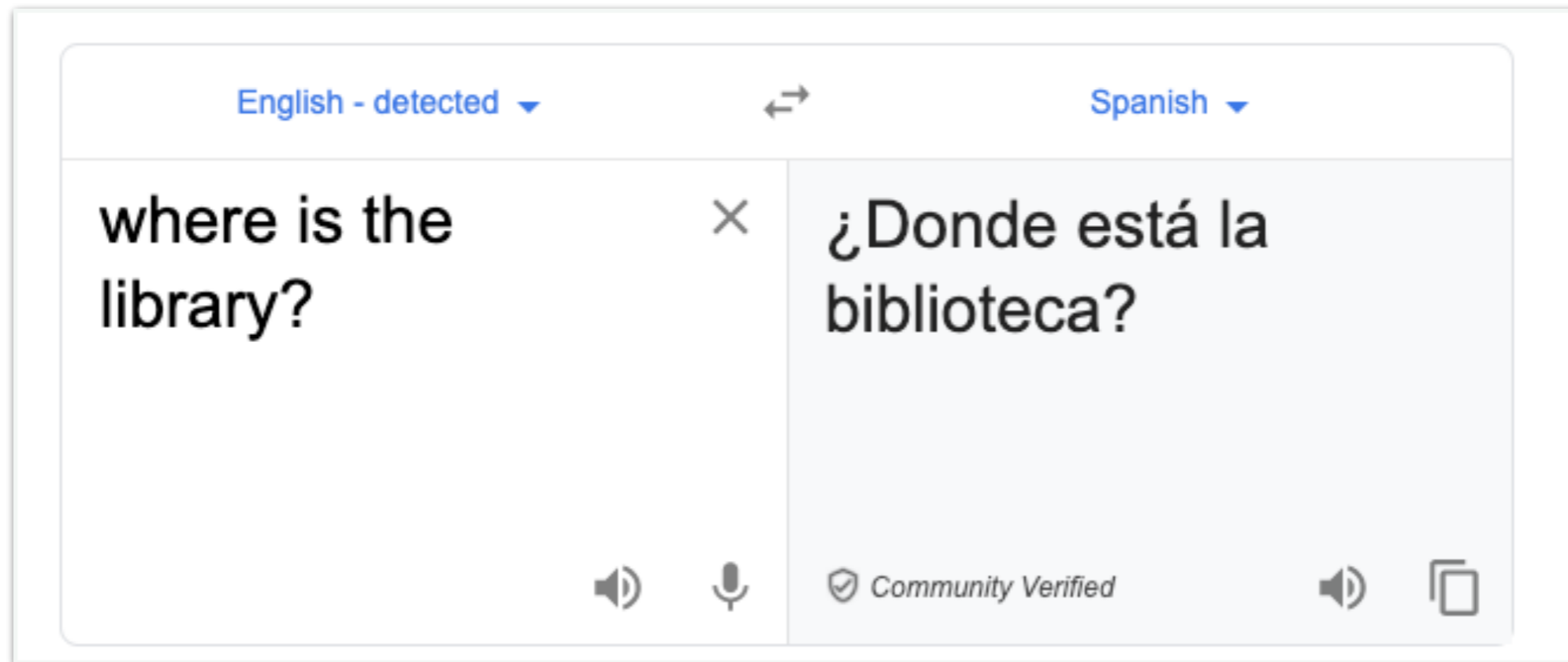

Spanish

*donde*      *esta*      ...      *la*      *bibliotheque?*  
 $y_1$        $y_2$       ...       $y_{T-1}$        $y_T$



English

$x_1$        $x_2$       ...       $x_{T-1}$        $x_T$   
*where*      *is*      ...      *the*      *library?*

# Motivating Example: Sequence Captioning

Input





# Motivating Example: Sequence Captioning

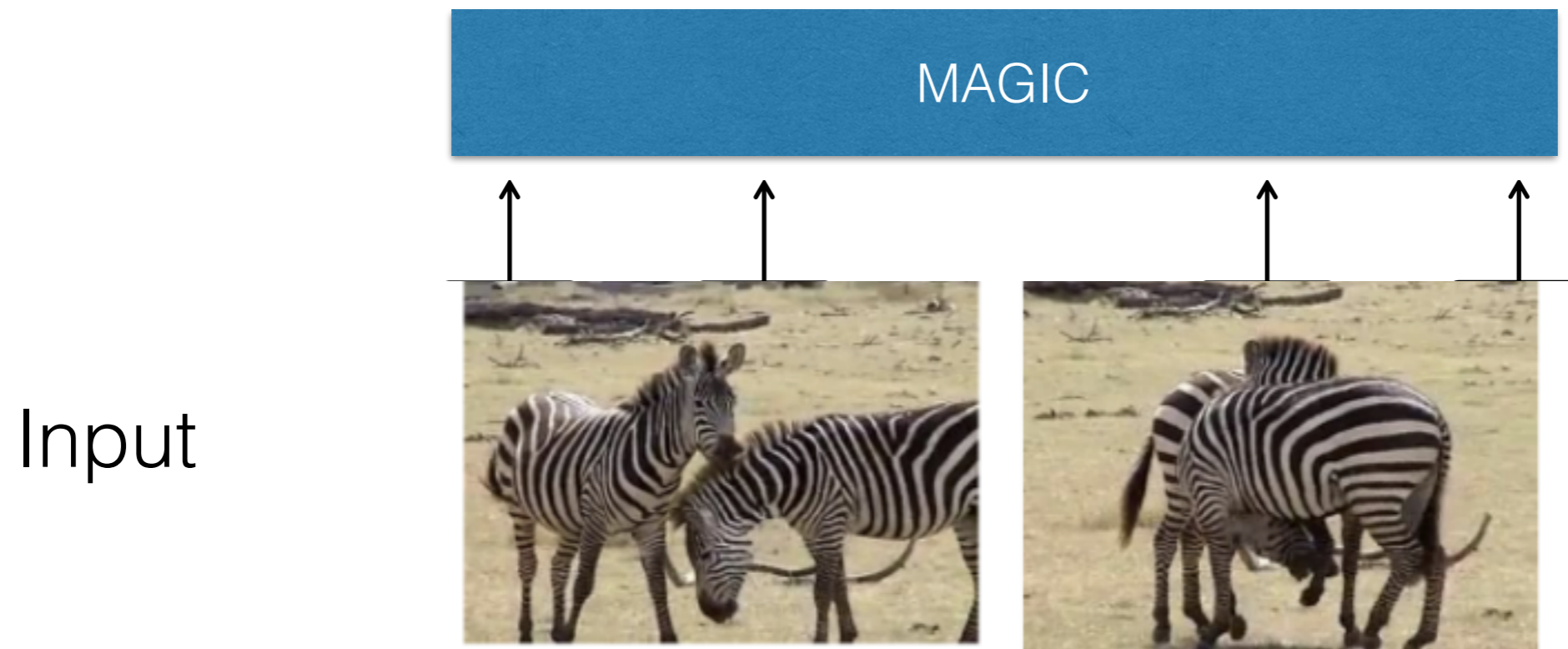

# Motivating Example: Sequence Captioning

Output S2VT: A herd of zebras are walking in a field.



Input

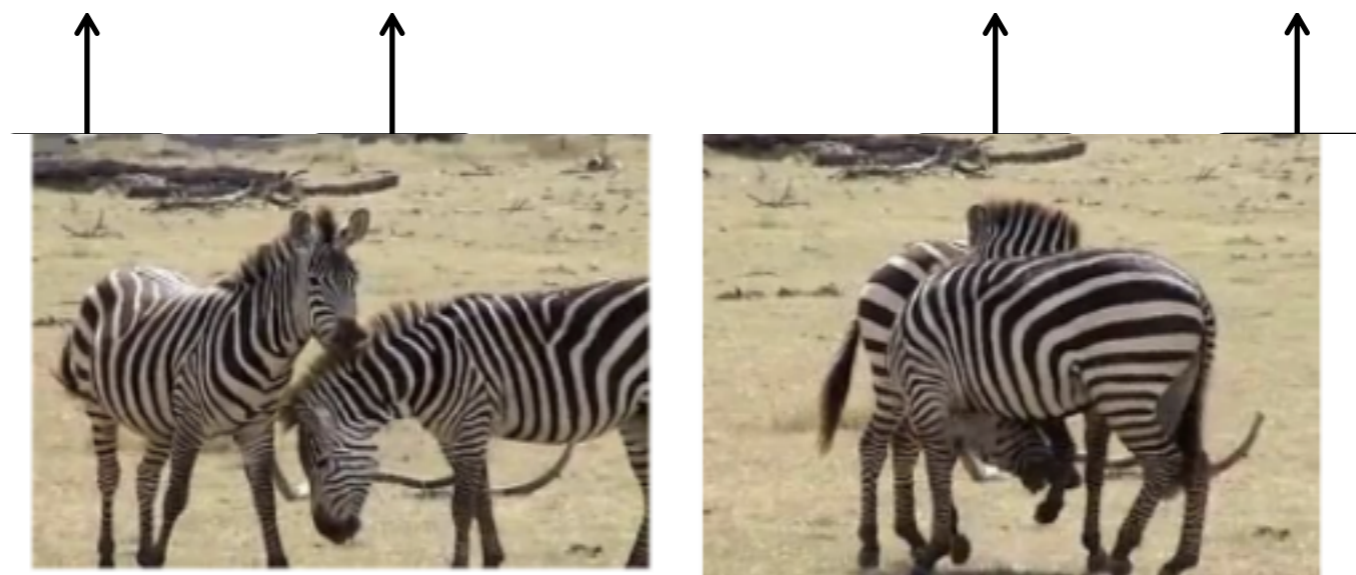

MAGIC

# *Encoder-Decoder* Models

Encoder



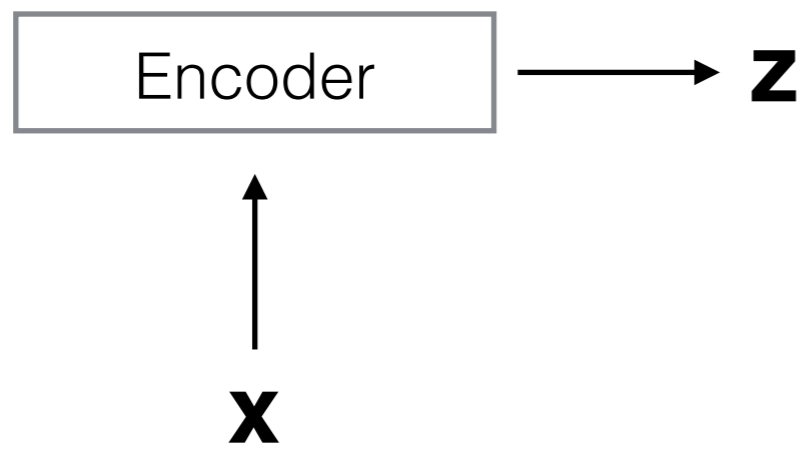

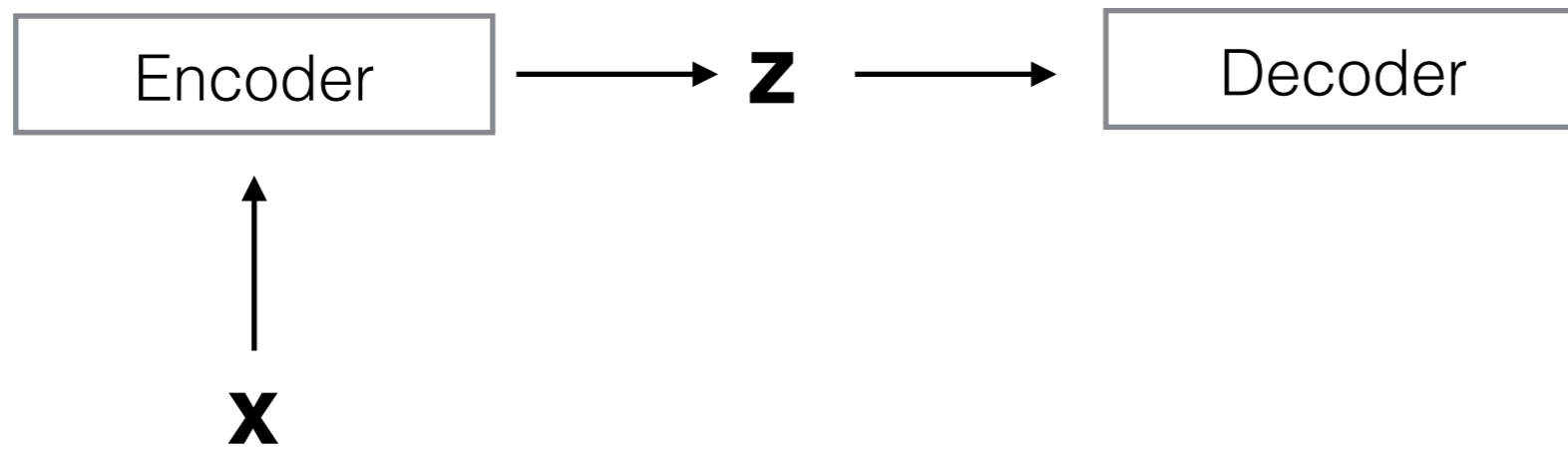

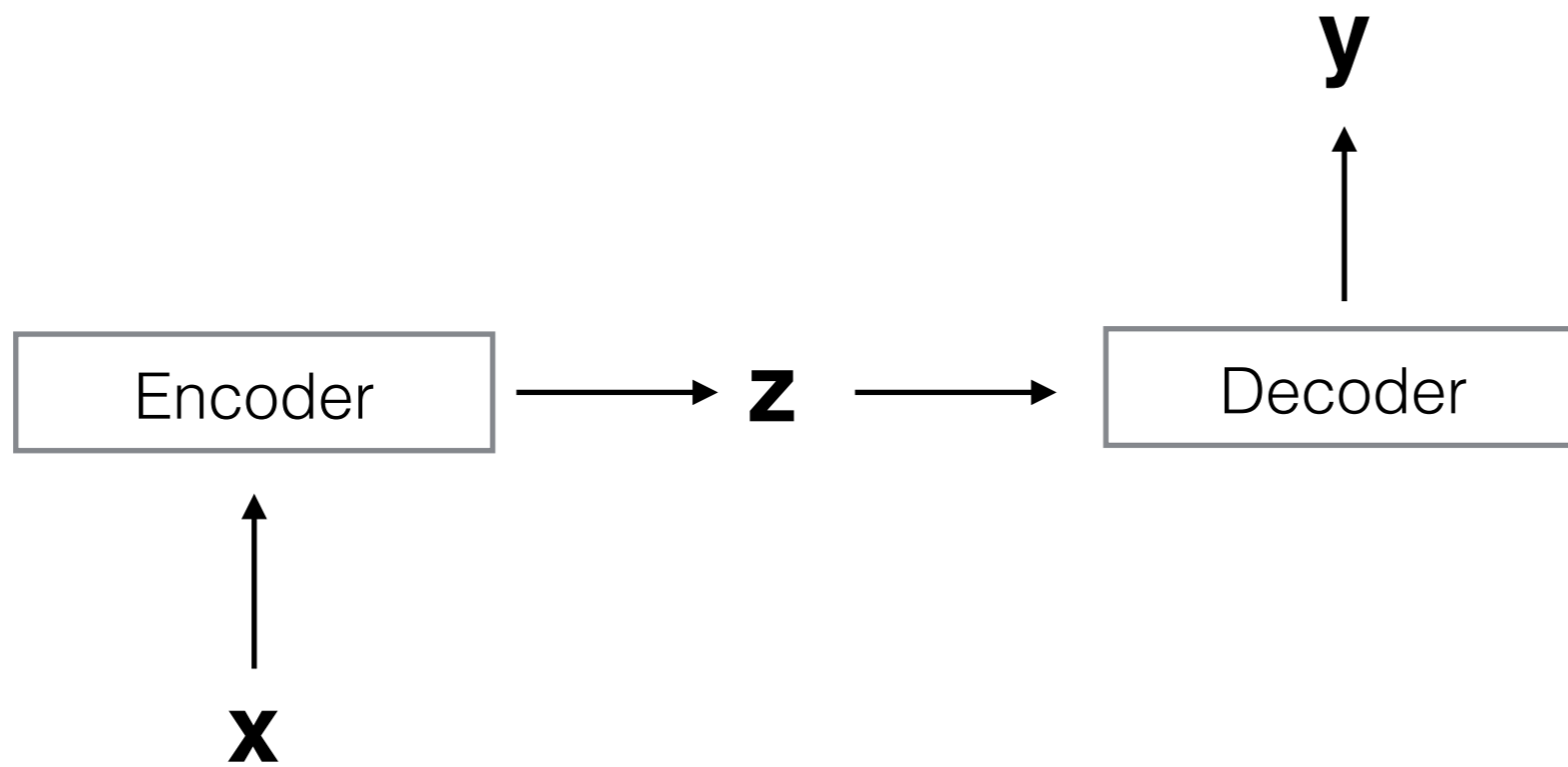



# Recall: Auto-Encoders

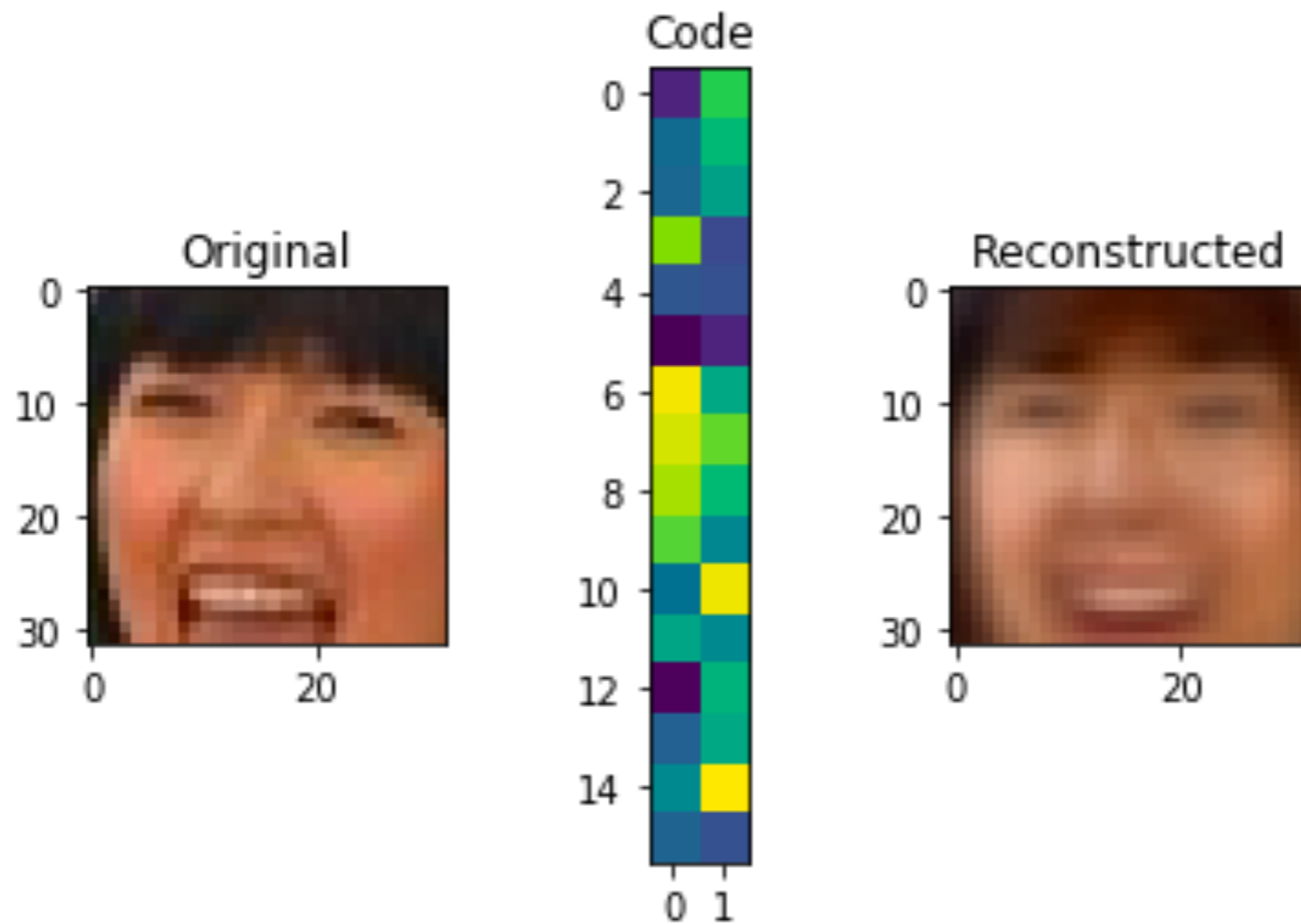

# RNN encoder



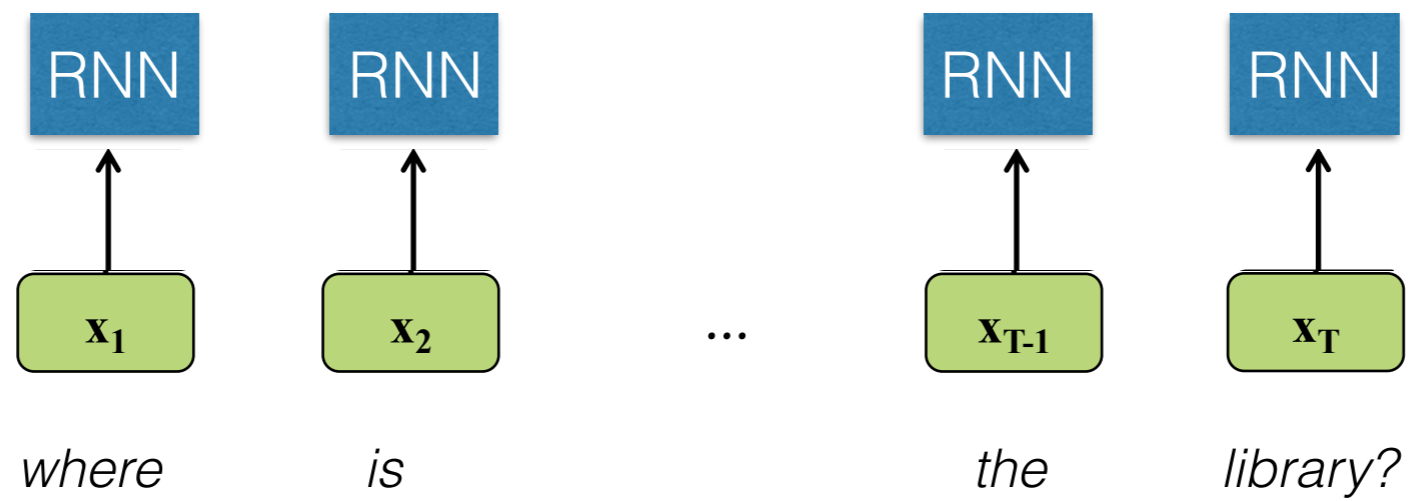

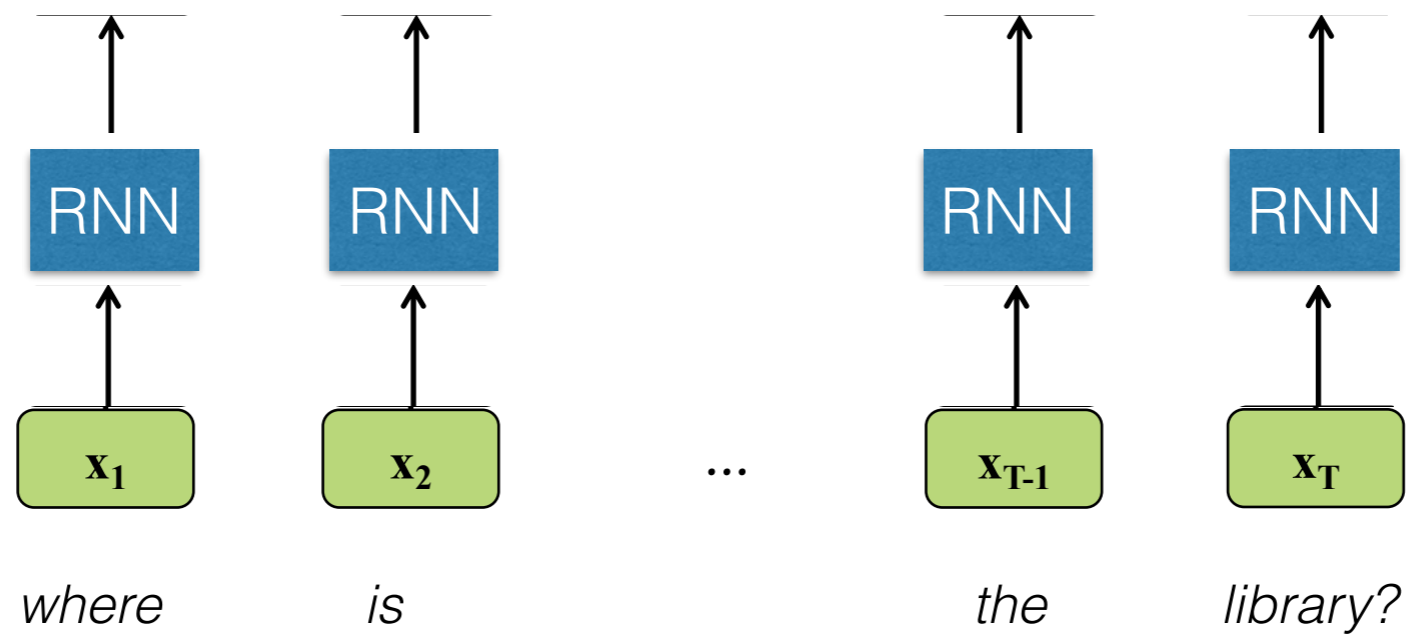

*Encoder*

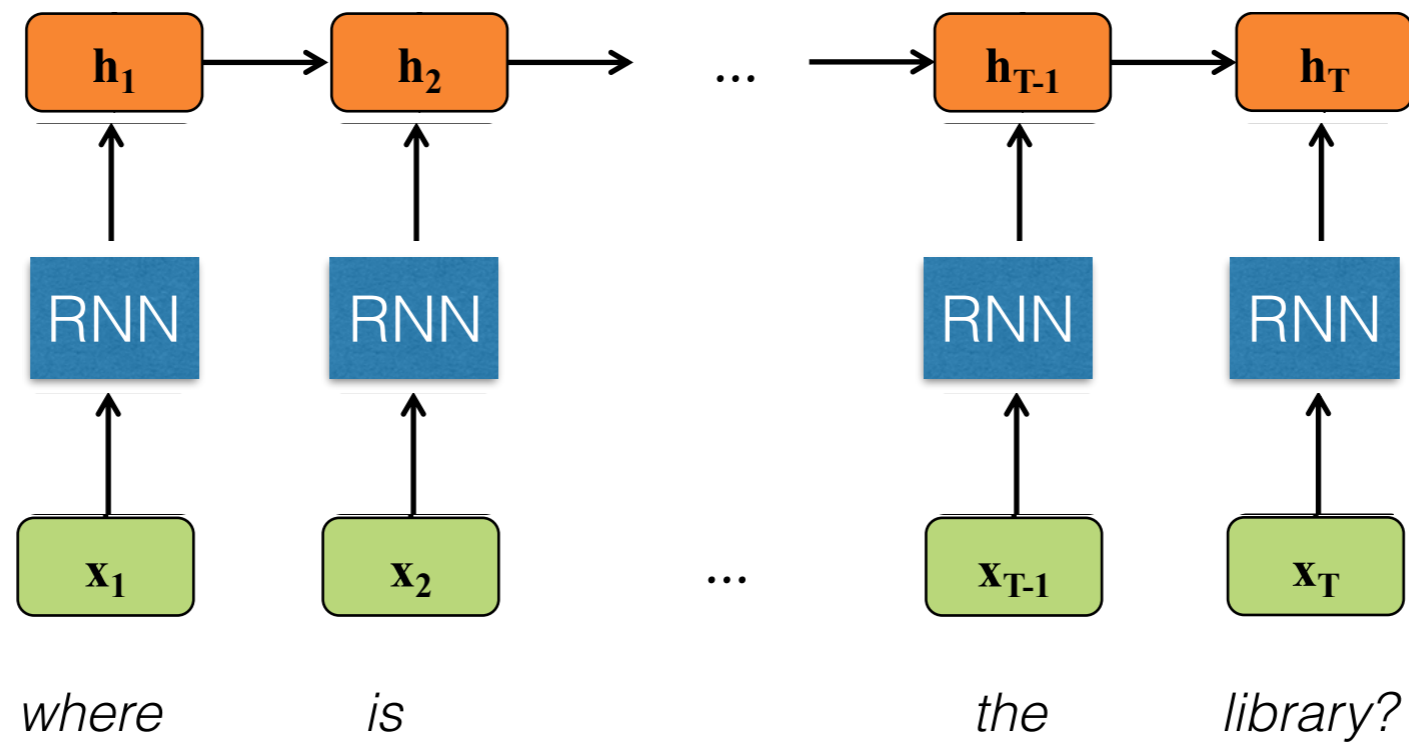

# RNN refresher

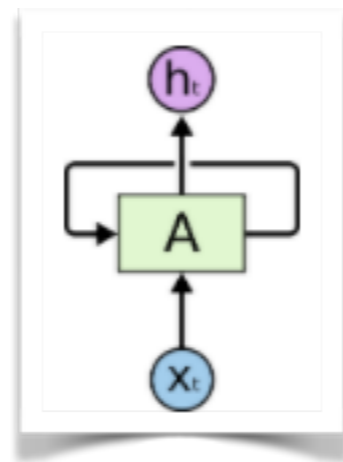

# RNN refresher

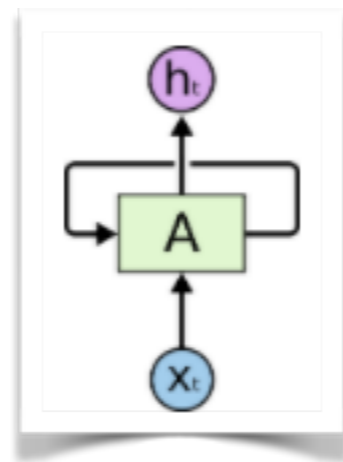

$$h_t = f_{\theta}(x_t, h_{t-1})$$

# RNN refresher

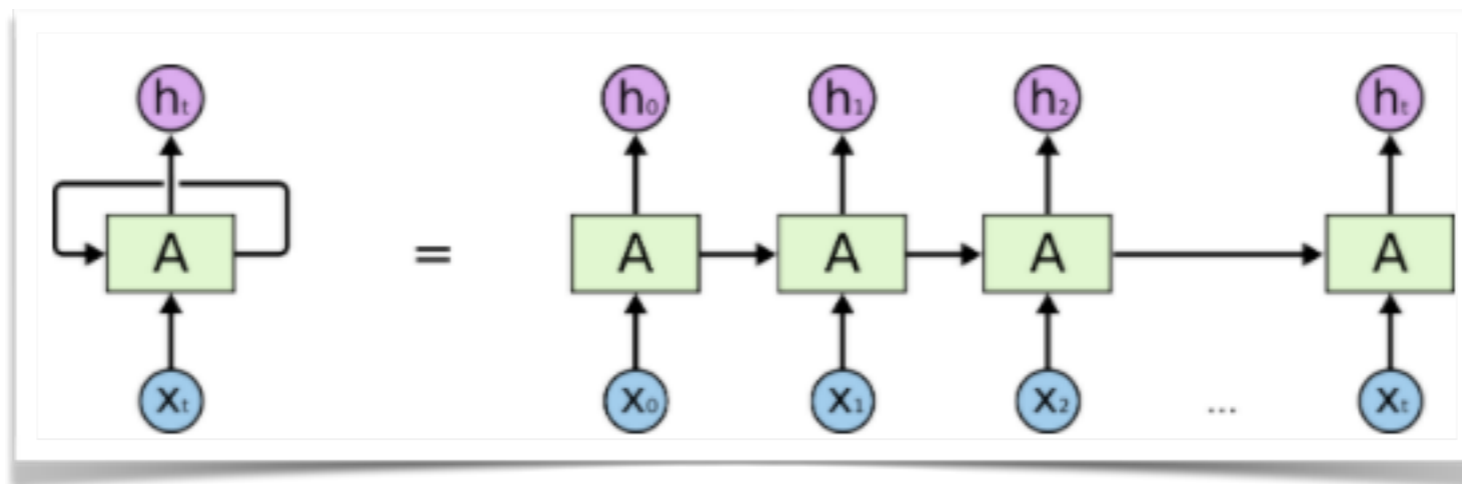



*Encoder*

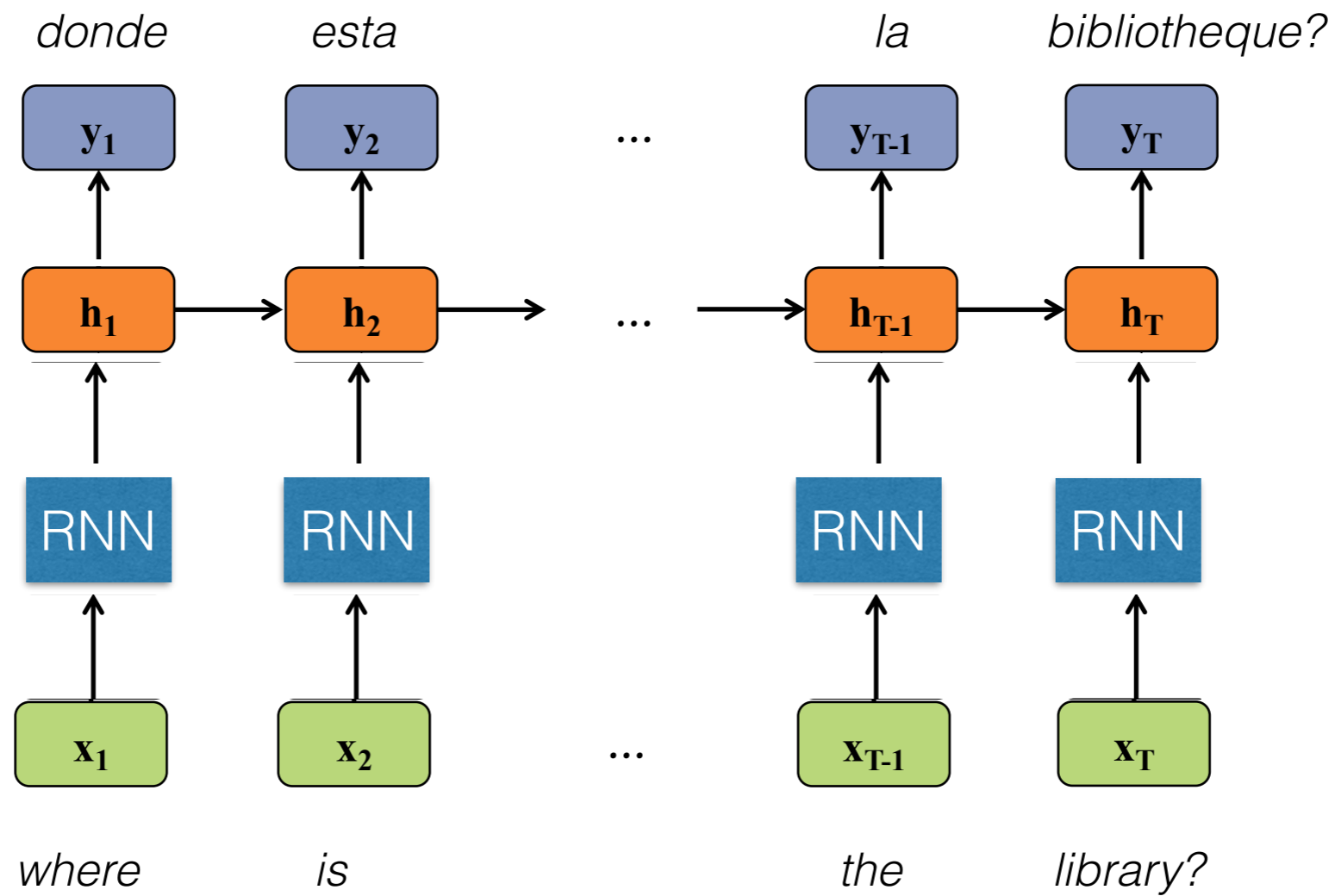

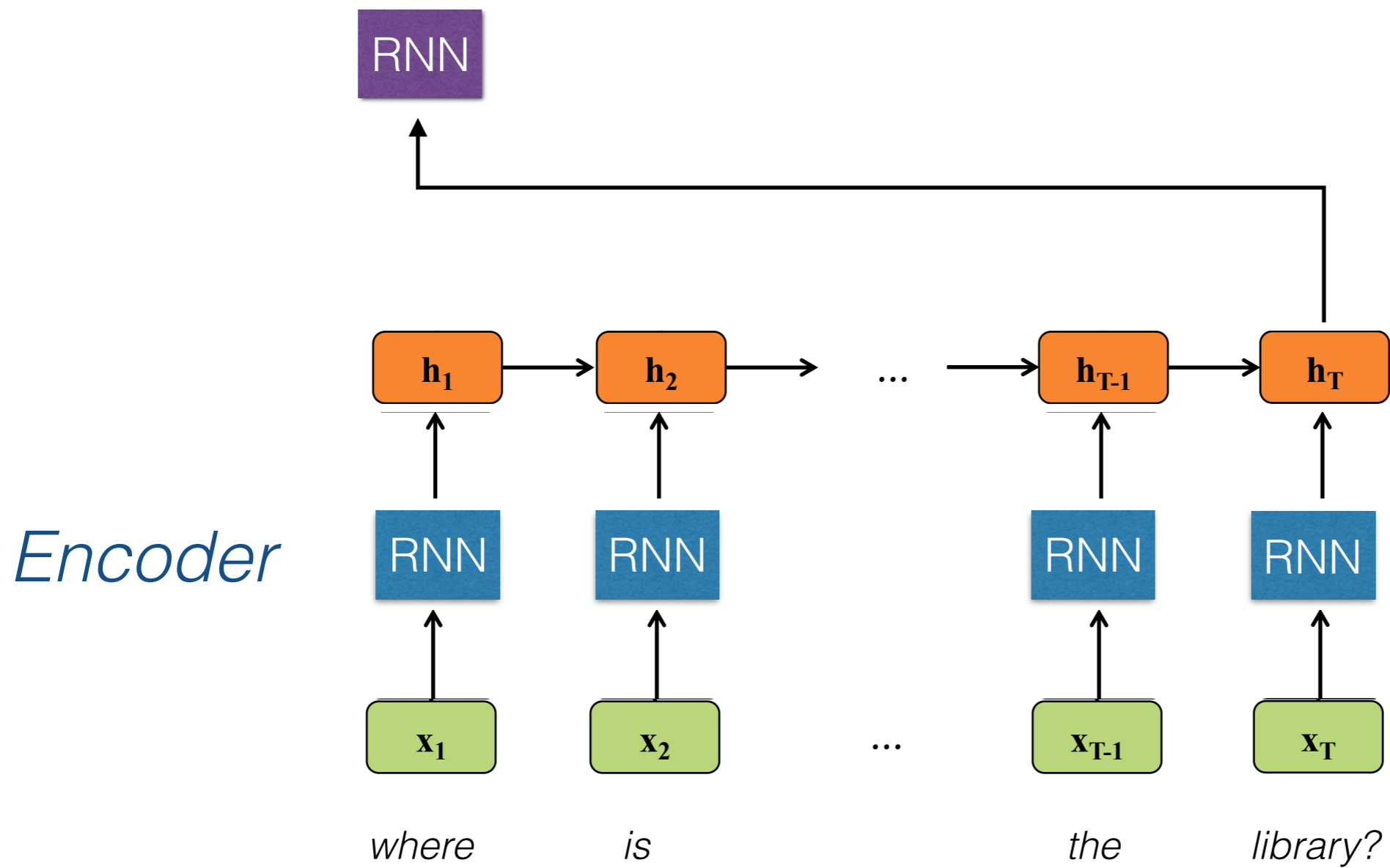

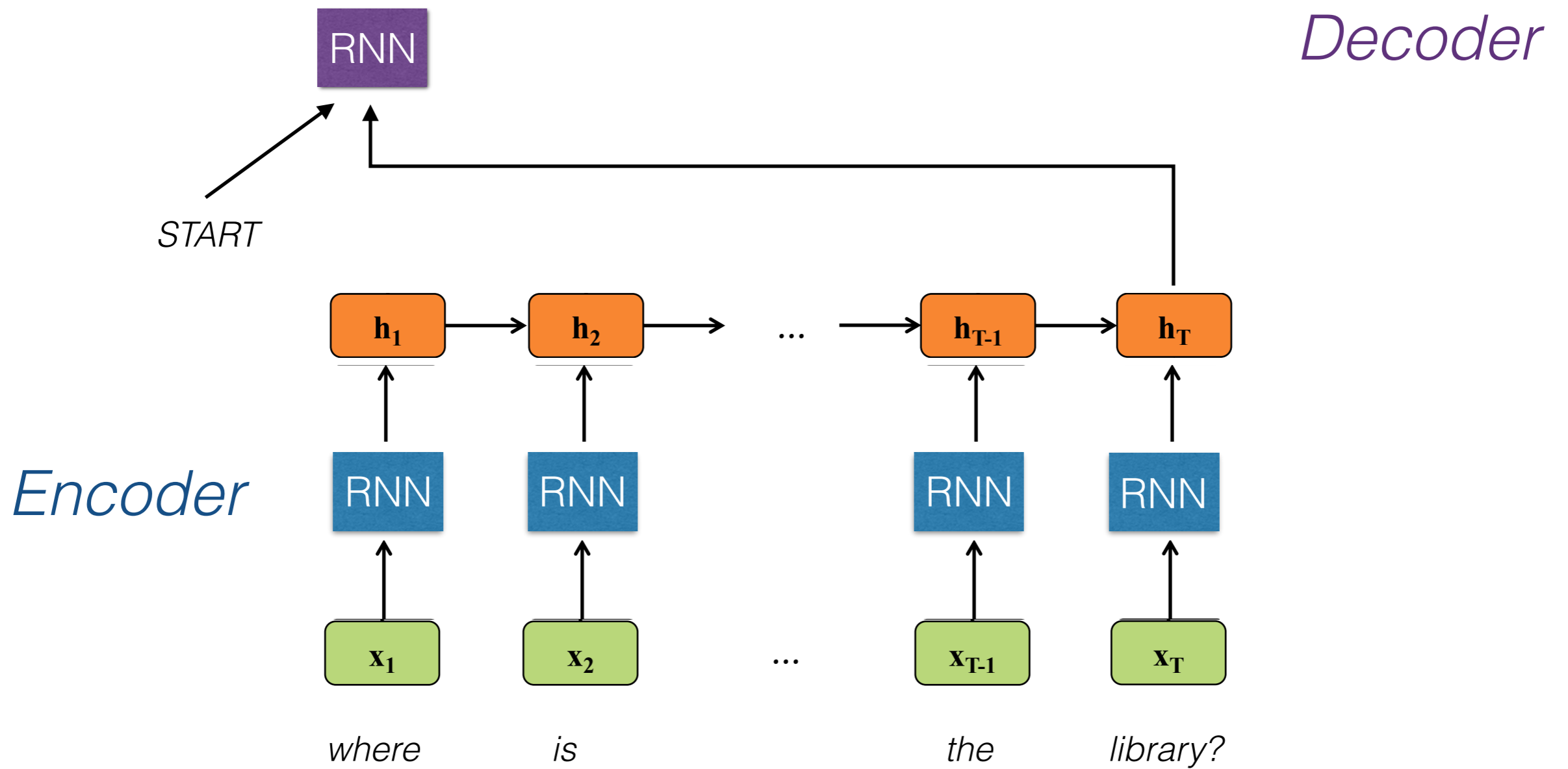

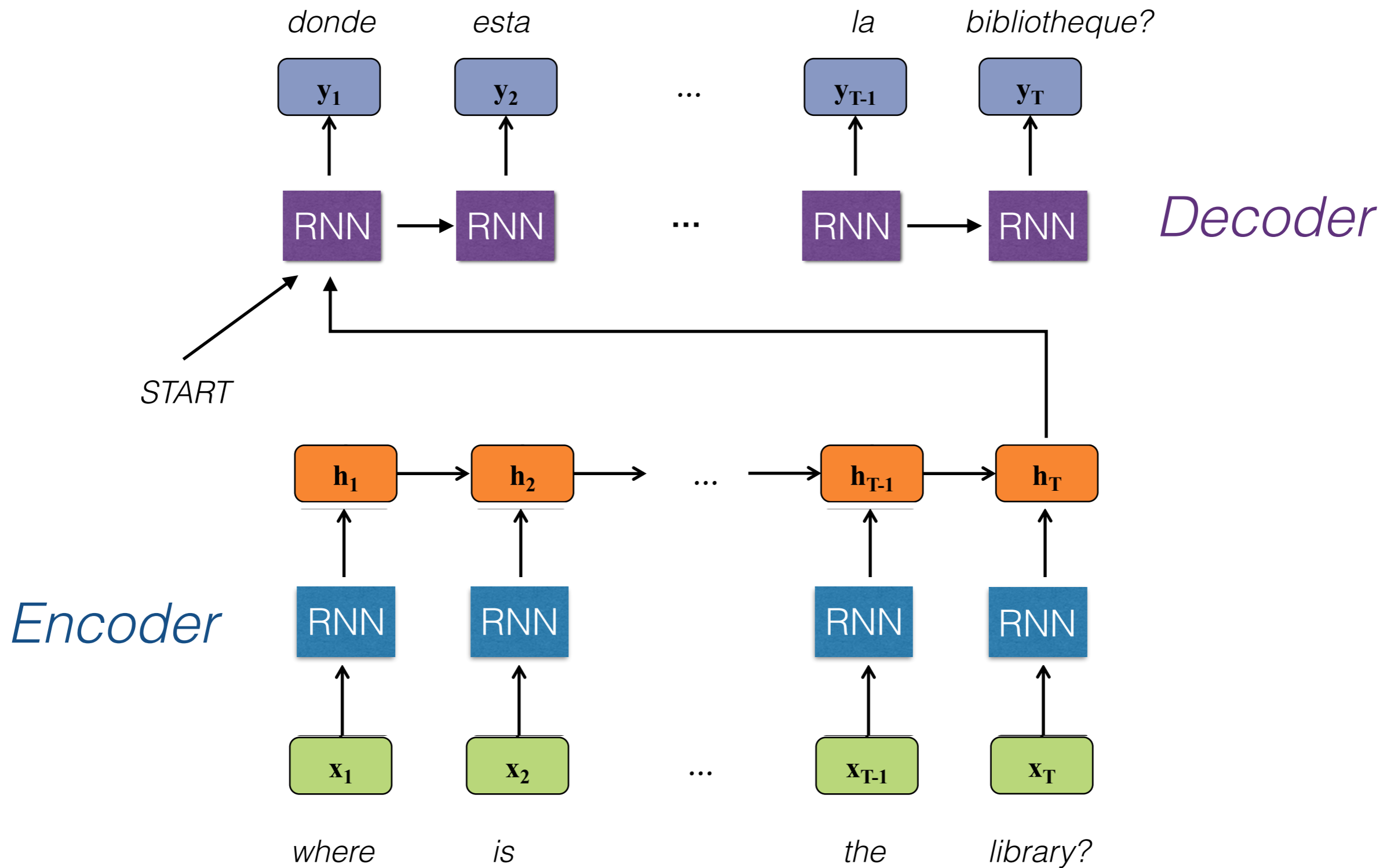

Let's think about a concrete example...

[https://colab.research.google.com/drive/1z\\_uyUjmXjpqbPwE7JWxYX116O0229aVK](https://colab.research.google.com/drive/1z_uyUjmXjpqbPwE7JWxYX116O0229aVK)