

SOLUTIONS

WRITE YOUR NAME CLEARLY IN THE BOX

CS5002

Spring 2024

Exam #1

February 21st, 2024

You will have the entire class period to complete the exam. Hand in the exam up front when you're done, and then you are free to leave.

Show your work throughout! Even if the answer boils down to yes/no or True/False, show us how you got there.

You may bring one 8.5x11-inch piece of paper, with anything written or typed on it (one side only). You will submit this cheat sheet along with your exam, and you will not be permitted to use any other materials or notes during the exam.

You may not copy answers from another student, or allow other students to copy your answers. Cheating of any kind is considered a violation of Northeastern University's academic integrity policy and will be reported to the Dean of Student Affairs.

No cell phones or other devices are allowed during the exam at any time. You will be dismissed if you are seen with one out. Please do not talk during the exam. If you have a problem or question, please quietly come up to the front of the room and ask.

Question	Total Points
Part I: Logic and Truth Tables	24
Part II: Circuits and Numbers	17
Part III: Sets and Counting	13
Total	54

SOLUTIONS

Part I: Logic and Truth Tables

SOLUTIONS

Question 1	9 points total
-------------------	-----------------------

Consider the statements P , Q , R , and T below.

P = Keith wears sunglasses

Q = The sun is shining

R = It is cloudy

T = Keith takes the bus

Translate the following English sentence into logical statements, using only the symbols \neg , \wedge , \vee , and/or \Rightarrow .
--

A Keith wears sunglasses only if the sun is shining

Solution: $P \Rightarrow Q$

Translate the negation of each of the following English sentences into logical statements, using only the symbols \neg , \wedge , \vee , and/or \Rightarrow . Simplify your response as much as possible.
--

B It's either cloudy or the sun is shining

Statement: $(\neg Q \wedge R) \vee (Q \wedge \neg R)$

Negation: $(Q \wedge R) \vee (\neg Q \wedge \neg R)$

C If the sun is not shining, Keith does not take the bus.

Statement: $\neg Q \Rightarrow \neg T$

Negation:

$\neg(\neg Q \Rightarrow \neg T)$

$\neg(\neg\neg Q \vee \neg T)$

$\neg(Q \vee \neg T)$

$\neg Q \wedge \neg\neg T$

$\neg Q \wedge T$

definition of implication

double negation

Demorgan

Double negation

SOLUTIONS

Question 2

6 points total

Use a truth table to show that $\neg(\neg p \wedge (p \vee \neg q)) \equiv p \vee q$. For full credit, keep the steps small -- apply just one operation per column.

Solution

p	q	$p \vee q$	$\neg p$	$\neg q$	$p \vee \neg q$	$\neg p \wedge (p \vee \neg q)$	$\neg(\neg p \wedge (p \vee \neg q))$
T	T	T	F	F	T	F	T
T	F	T	F	T	T	F	T
F	T	T	T	F	F	F	T
F	F	F	T	T	T	T	F

SOLUTIONS

Question 3	9 points total
-------------------	-----------------------

Our universe is all candy sold in the US. The predicates below are applicable to any candies x, y :

- $\text{choc}(x)$... Candy x contains chocolate
- $\text{nut}(x)$... Candy x contains nuts
- $\text{pop}(x)$... Candy x is popular
- $\text{comp}(x, y)$... Candies x and y are made by the same company

Using these predicates, quantifiers \forall, \exists and logical symbols \vee, \wedge, \neg and/or \Rightarrow express each English statement below in propositional logic:

A Milky Ways have chocolate, but no nuts

Solution:

$$\text{choc}(\text{milky way}) \wedge \neg \text{nut}(\text{milky way})$$

B All popular candies contain nuts

Solution:

$$\forall x \text{ popular}(x) \Rightarrow \text{nut}(x)$$

C For every candy with nuts, there is a different candy made by the same company which doesn't have nuts.

Solution:

$$\forall x \exists y \text{ nut}(x) \Rightarrow (x \neq y) \wedge \text{comp}(x, y) \wedge \neg \text{nut}(y)$$

SOLUTIONS

Part 2: Circuits and Numbers

SOLUTIONS

Question 4	9 points total
-------------------	-----------------------

A

Convert the unsigned number $4C_{16}$ to decimal.

Solution:

$$12 \cdot 1 + 4 \cdot 16 = 12 + 64 = 76_{10}$$

B

Convert your decimal number from Part A to unsigned binary.

Solution:

$$76_{10} = 64 + 8 + 4 = 1001100_2$$

C

Now, let's consider the negative value of your answer for Part B. Represent it in 8-bit two's complement. (I.e., if your answer to Part B was a , represent $-a$ in two's complement.)

Solution:

We need to represent -76_{10} in 8-bit two's complement.

First, expand out the original answer to 8 bits (it was 7 before): 0100 1100

Next, flip the bits: 1011 0011

Next, add one: 1011 0100

SOLUTIONS

Question 5

8 points total

A Write a logical expression that directly expresses the following circuit

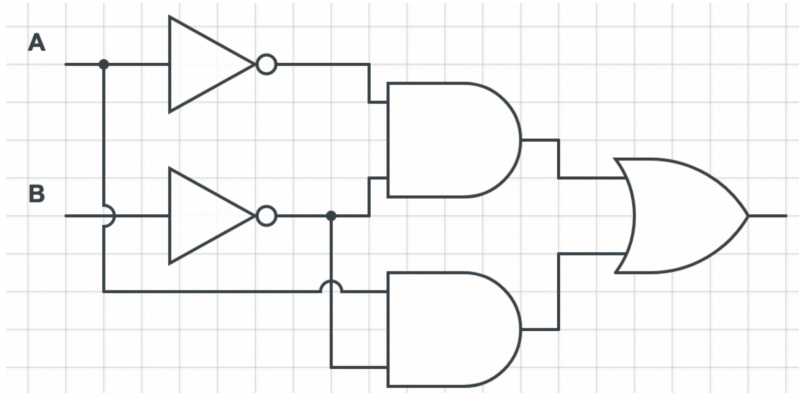

Solution

$$(\neg A \wedge \neg B) \vee (A \wedge \neg B)$$

B List all values of A and B that would make the circuit result in a value of 0.

Solution:

Circuit is 0 when $A = 0, B = 1$, or when $A = 1, B = 1$

SOLUTIONS

Part III: Sets and Counting

SOLUTIONS

Question 7	6 points
------------	----------

20 runners compete in the women's Olympic marathon in Paris, with 3 of them representing the US¹. We're interested in the medal-winners of the race: whoever comes in first, second, third.

How many ways can the top-three racers finish such that **at least one** of the US runners gets a medal? Report your answer as an expression.

Solution:

Subtraction rule solution

The easiest thing is to count all the ways to have a top-3 without any of the US runners, and subtract from the total. Order matters, because we have a first, second, and third place.

Without any restrictions...

- 20 ways to pick first place AND
- 19 ways to pick second place AND
- 18 ways to pick third place

$$20 \cdot 19 \cdot 18$$

With the restriction that we can't pick ANY of the US runners for the top 3...

17 ways to pick first place AND

16 ways to pick second place AND

15 ways to pick third place

$$17 \cdot 16 \cdot 15 \text{ ways}$$

Subtraction rule gives us $(20 \cdot 19 \cdot 18) - (17 \cdot 16 \cdot 15)$

$$= 2760 \text{ ways to have at least one US runner in the top 3.}$$

Bottom-up solution:

- Case 1: One US runner wins a medal. $3 \cdot 17 \cdot 16 \cdot 3 = 2448$
- Case 2: Two US runners win medals: $3 \cdot 2 \cdot 17 \cdot 3 = 306$
- Case 3: Three US runners win medals: $3 \cdot 2 \cdot 1 = 6$
- Case 1 OR case 2 OR case 3: $2448 + 306 + 6 = 2760$

¹ Fiona O'Keeffe, Emily Sisson, and Dakotah Lindwurm will be the three representing the US this summer!

SOLUTIONS

SOLUTIONS